

The Bray logo is displayed in a large, bold, red font, oriented vertically on a white rectangular background.

**SERIES 39L**

Long Body Slurry Control Valve  
50nb - 500nb (2" - 20")

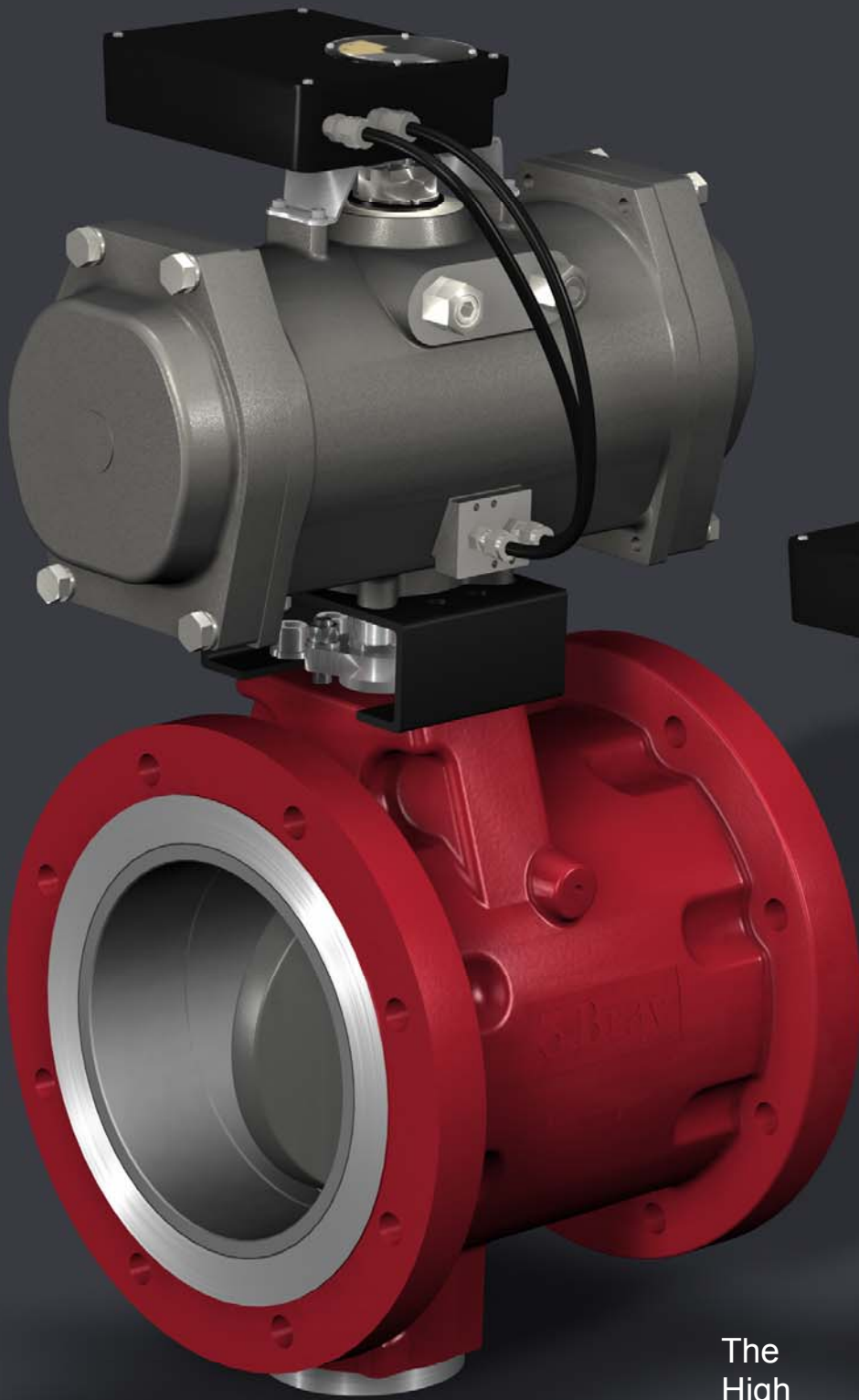

The  
High  
Performance  
Company

Presents the Ultra High Performance  
**BRAY SERIES 39**

# SERIES 39L

## HIGH PERFORMANCE BUTTERFLY VALVE FOR HIGHLY EROSIVE SLURRY CONTROL

SIZE RANGE  
50nb-500nb (2"-20")

## WAFER and FLANGED LONG BODY DESIGN, SINGLE OFFSET DISC

Bray Controls proudly offers the Series 39 high performance slurry control valve. The Series 39 has been designed to withstand the most highly erosive and abrasive services in alumina refining. It has also been successfully applied to other applications where control of erosive product is required.

The Bray Series 39 control valve is made to the highest standard from technically advanced wear resistant materials such as sintered silicon carbide ceramic, partially stabilized zirconia ceramic and special chrome-molybdenum iron. Therefore, Series 39 is the ultimate product for use on severely erosive slurry and abrasive applications.

Components from the patented Series 40 high performance valve are featured in the Series 39. Proven Series 40 parts, such as seals, packing and bearings, and the blow out proof stem design are utilized. Industry standard ISO actuator mounting top works allows for simple, standard on-site actuator fitment.

The Series 39 high performance slurry control valve delivers the highest quality and best value available to meet the requirements of today's fluid process industry.

**BODY:** In sizes 50nb to 150nb (2" to 6") a compact wafer style ductile iron body enables easy installation. In sizes 200nb (8") and larger double flanged bodies provide a method of installation and alignment more suited to larger, heavier valves. The larger size valves have lifting points provided on the body casting. 316 stainless steel bodies are available in some smaller sizes.

**STEM:** One piece high strength 17-4 PH stainless steel stems are used in all sizes. The valve stem is standardized to allow for interchangeability of Bray actuators.

**DISC:** The disc has been designed to maximize flow and minimize wear. The disc is available in chrome-molly iron or PSZ ceramic.

### BLOW OUT PROOF STEM:

The Series 39 valve features blow-out proof stem protection. A retaining ring is installed between the machined stem groove and gland retainer step providing full retention of the stem in the unlikely event of internal stem failure.

### ADJUSTABLE PACKING:

The stem packing features easy access to adjusting hex head nuts without requiring removal of the actuator. The system consists of studs, hex head nuts, lock washers, gland retainer, gland ring and seal rings. A slight quarter turn of the hex nuts is usually all that is required, should any field adjustment ever be needed.

Both hex head nuts must be evenly adjusted and never over tightened.

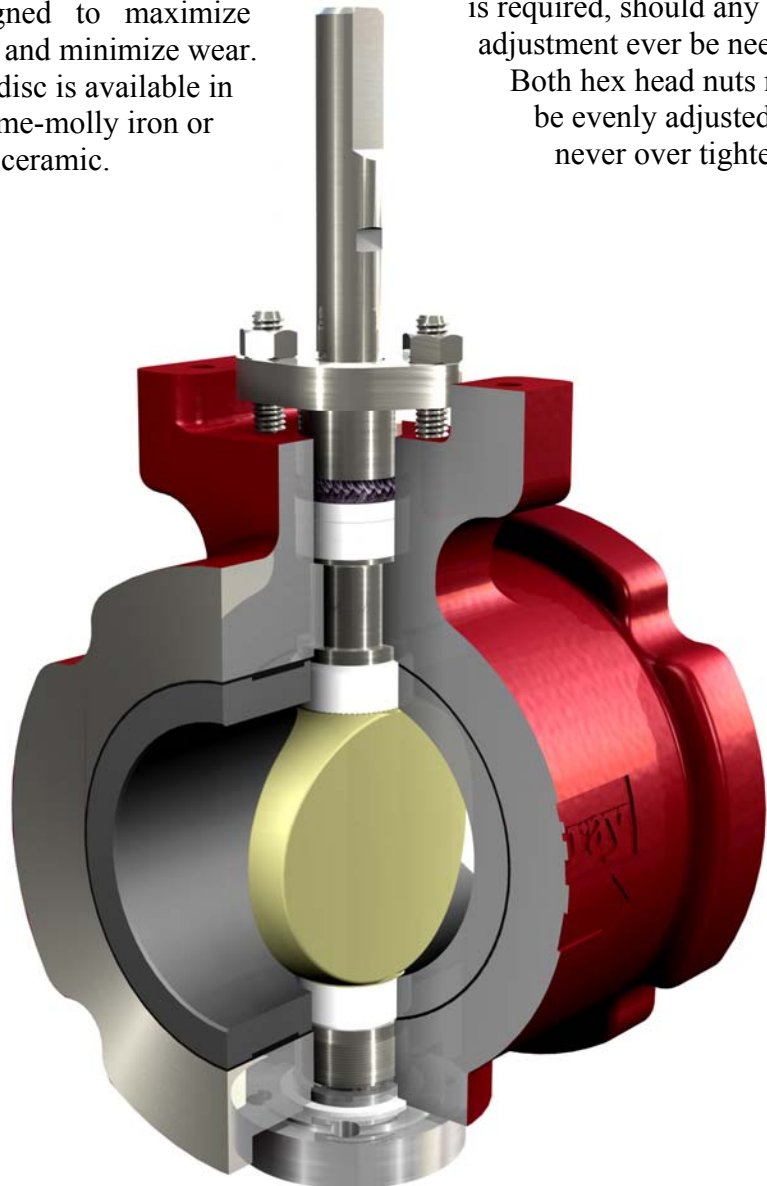

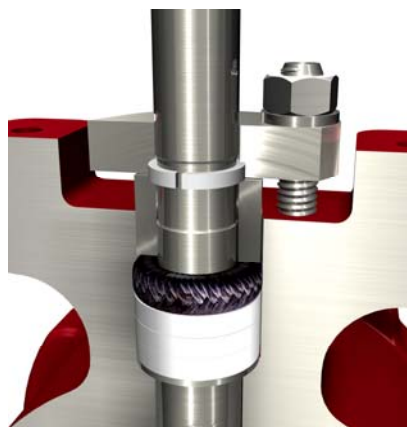

**STEM SEAL:** The stem seal system derived from the S40 provides a positive seal. PTFE packing seals the stem and a carbon fibre anti-extrusion ring contains the packing. Flexible graphite rings are available for high temperature applications. All Series 39 valves have one set of stem seal packing rings and a PTFE base cover gasket or O-ring seal in the body base.

**STEM BEARINGS:** The upper stem bearing has a 316 stainless steel shell with a TFE / glass fibre liner bearing surface. The lower stem bearing is PSZ ceramic. The upper and lower stem bearings provide excellent resistance to corrosion and distortion caused by mechanical loading and high temperatures.

**SWING THROUGH DISC:** As the Series 39 is a control valve only, the disc does not seat off on the liner. It can in fact swing through 360 degrees.

**PSZ HUBS:** The Series 39 disc is held in position by two cylindrical ceramic hubs. These hubs act as a running surface with minimal clearance to the disc, whilst allowing the disc to rotate.

**SINGLE OFFSET DISC:** The single offset disc is the heart of the Series 39 valve. A butterfly valve disc is most prone to wear in the first 25% of opening. The single offset disc design allows the disc to open the leading edge first (left side as pictured below). This in effect causes a larger opening in the foremost position of the valve, in turn allowing the high velocity fluid the most amount of distance to recover whilst still inside the ceramic lined valve. The operating fluid is also effectively deterred from accelerating across the front face of the disc minimizing wear in regions such as the upper and lower hubs.

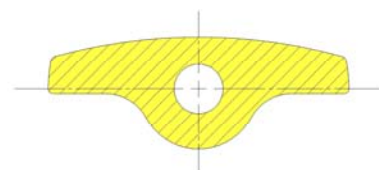

The disc is driven by either a hex or double D connection to the stem, which not only provides a means of easily servicing the stem and disc, but importantly eliminates any torque transmitting drive components being directly in contact with the abrasive process fluid.

**CERAMIC LINER:** The series 39 liner is made from Sintered Silicon Carbide Ceramic. The Vickers hardness of S-SiC Ceramic is 2,460 meaning the internal liner in the Series 39 valve is extremely durable. In most applications the liner will outlast the hard wearing single offset disc (iron or ceramic). Therefore, not only is the valve long lasting, but maintenance is very cost effective as only a minimal number of parts, such as the disc, stem, bearings and stem seals, should ever require servicing. The S-SiC liner is diamond ground to a very tight final tolerance and is bonded into the body with a chemical and heat resistant agent.

**BASE PLUG & COVER:** The opening in the base of the valve is sealed by a SS base cover. The base cover also locks the base plug at its final position after it has been adjusted. The base plug is responsible for providing the adjustable means to position and give clearance to the two PSZ hubs in relation to the disc and its position in the centre of the valve's bore.

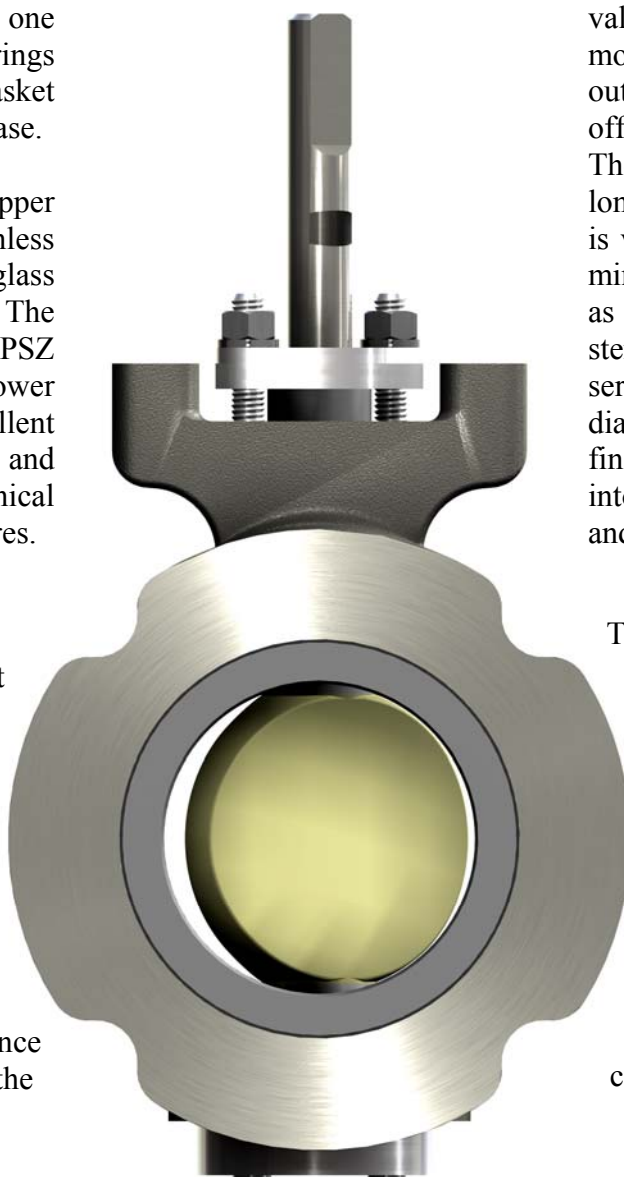

# DIMENSIONS

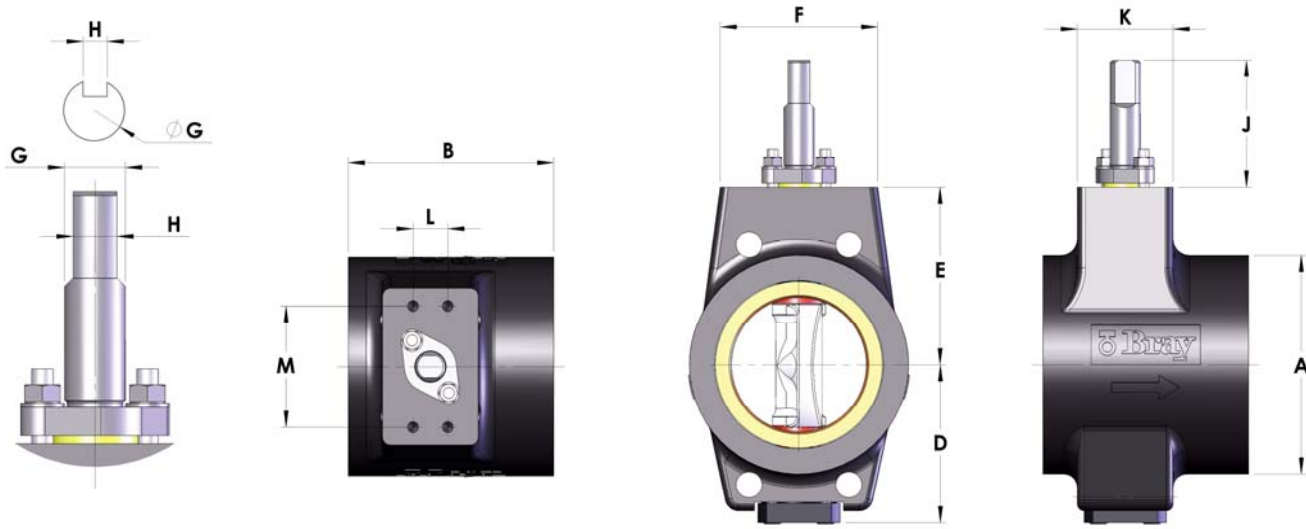

## DIMENSIONS

Size		A	B	D	E	F	G	H	J	K	L	M	Mtg Details Std Bracket		Mass Kgs
ins	mm												Act'r Mtg	Stem Height	
2	50	117	80	68	104	100	15.9	11.0	85	50	19.05	79.25	F07	32	6
3	80	150	120	81	115	100	15.9	11.0	85	50	19.05	79.25	F07	32	10
4	100	160	150	116	130	115	22.0	16.0	92	70	25.4	88.9	F12	32	17
6	150	216	230	142	142	115	22.0	16.0	92	70	25.4	88.9	F12	32	35
8	200	343	305	202	180	140	30.0	22.0	108	80	28.6	111.1	F12	51	89
10	250	406	380	227	215	140	30.0	22.0	108	80	28.6	111.1	F12	51	134
12	300	483	455	253	253	140	30.0	22.0	108	80	28.6	111.1	F12	51	205
14	350	533	475	379	356	264	50.0	12x10	89	100	50.8	222.2	F16	64	290
16	400	597	500	394	425	264	50.0	12x10	89	100	50.8	222.2	F16	64	360
18	450	635	550	431	483	264	63.5	15.88 <sup>2</sup>	127	100	50.8	222.2	F16	102	410
20	500	700	600	465	552	264	63.5	15.88 <sup>2</sup>	127	100	50.8	222.2	F16	102	490

End connection is to suit ASME B16.5 Class 125/150 flanges and is standard in all sizes.

### Cv VALUES - VALVE SIZING COEFFICIENT

Size		90°	80°	70°	60°	50°	40°	30°	20°	10°
ins	mm									
2	50	84	75	59	46	29	19	10	6.4	4
3	80	196	192	168	128	88	60	35	18	8
4	100	355	346	303	232	158	107	62	31	12
6	150	1280	1140	898	608	380	241	144	78	34
8	200	2555	2260	1788	1200	746	468	275	149	59
10	250	4120	3600	2540	1800	1065	696	408	212	86
12	300	6500	5820	4610	3110	1930	1190	715	369	140
14	350	7800	6985	5570	3750	2340	1440	860	446	169
16	400	10350	9325	7440	5010	3120	1880	1150	588	222
18	450	12190	11420	9450	6575	4190	2530	1375	626	248
20	500	15470	14485	11900	8300	5300	3190	1750	794	268

The above Cv values are based on theoretical calculations.

### OPERATING TORQUE Nm

Size		Normal		Severe	
ins	mm	7bΔP	16bΔP	7bΔP	16bΔP
2	50	25	27	34	38
3	80	33	36	45	50
4	100	46	52	65	74
6	150	100	121	142	167
8	200	187	219	246	291
10	250	313	360	433	494
12	300	458	545	602	743
14	350	668	799	873	1082
16	400	957	1175	1240	1585
18	450	1362	1667	1749	2232
20	500	1729	2113	2207	2811

The above torque values are for:  
 Normal: light to medium slurries  
 Severe: medium to heavy slurries



## MATERIALS OF CONSTRUCTION

# MATERIALS

Item	Name	Material
1	Body	Ductile Iron ASTM A395
		Stainless Steel ASTM A351 CF8M
2	Disc	Chrome-Molly Iron (Hardened) PSZ Ceramic (Partially Stabilized Zirconia)
3	Stem	17-4 PH SS ASTM A564-Type 630
4	Liner	S-SiC Ceramic (Sintered Silicon Carbide)
5	Upper Hub	PSZ Ceramic (Partially Stabilized Zirconia)
6	Spacer	316 Stainless Steel ASTM A276-Type 316
7	Bearing	316 Stainless Steel with TFE & Glass Fabric Liner
8	Thrust Washer	316 Stainless Steel ASTM A276-Type 316
9	Stem Seal	PTFE Rings, plus 1 x Carbon Fibre Top Ring
10	Gland Ring	316 Stainless Steel ASTM A276-Type 316
11	Retaining Ring	18-8 Stainless Steel
12	Stud	316 Stainless Steel ASTM A193-B8M
13	Gland Retainer	316 Stainless Steel ASTM A276-Type 316
14	Lock Washer	18-8 Stainless Steel
15	Hex Nut	18-8 Stainless Steel

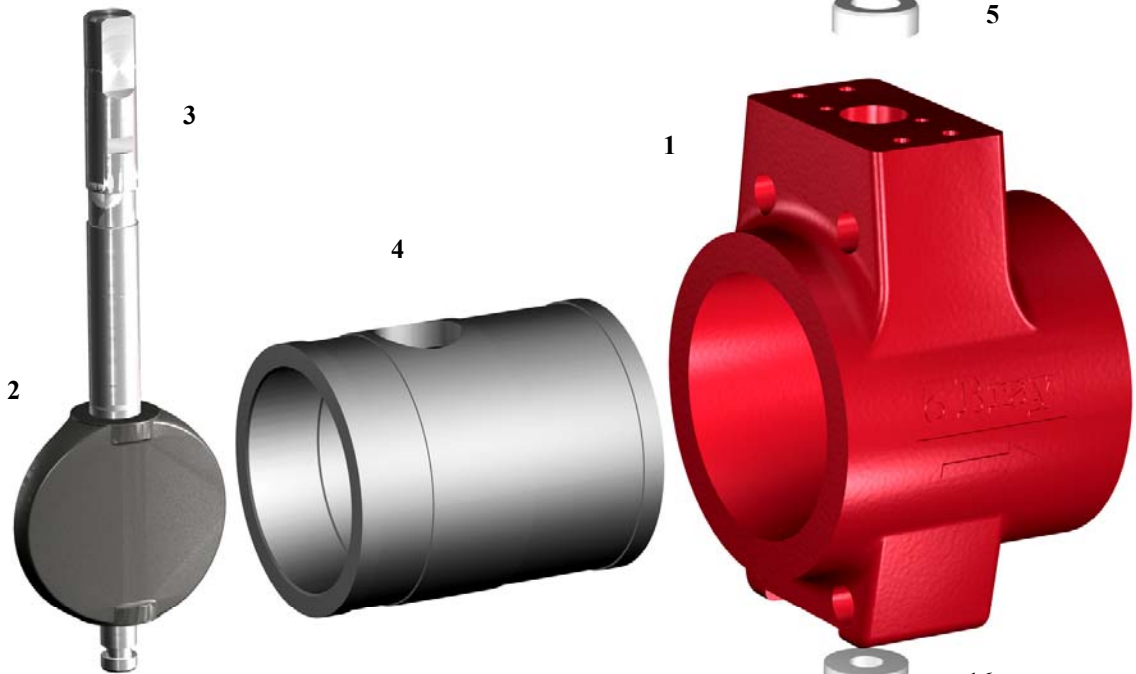
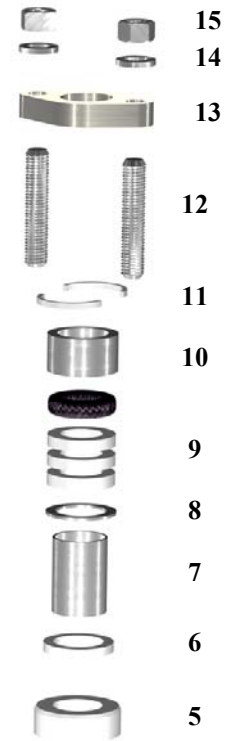

16	Lower Hub	PSZ Ceramic (Partially Stabilized Zirconia)
17	Stem Retainer	Tool Steel
18	Base Plug	316 Stainless Steel ASTM A276-Type 316
19	Gasket	PTFE
20	Base Cover	316 Stainless Steel ASTM A276-Type 316
21	Cap Screws	18-8 Stainless Steel

Other materials are available. Please consult factory for your specific application



Valves in sizes greater than 150nb (6") have the following additional components:  
 -AFLAS O-Ring and 316SS washer located between Upper Bearing and Spacer.  
 -316SS Stem retention assembly c/w PEEK thrust washers in lieu of tool steel rings.  
 Where required, standard ISO mounting bracket: 18-8 St Steel or Carbon Steel.

### DIRECTION OF FLOW:

The Series 39 long bodied control valve is designed to provide a longer distance down stream of the disc centreline than upstream. The longer distance downstream is to allow for recovery of turbulent flow before the process fluid re-enters the pipe work. Therefore, the valve needs to be installed so the direction arrow (that is cast on the side of the valve) is in line with the direction of flow. It is also important to make sure that the disc is positioned correctly in the relation to the direction of flow prior to fitting actuation (which is clearly outlined in the installation and maintenance instructions).



### PROTECTING FLANGE CONNECTION FACES:

To keep the flange connection surfaces free from any damage or any irregularities that may cause sealing problems during installation, it is essential that a valve is not laid on rough surfaces or dropped on these sealing faces. This can seriously damage the machined face or ceramic lining of the valve. During transportation it is recommended that these flange connection faces are protected by covers and ideally not packaged with the valve resting on a flange connection surface.

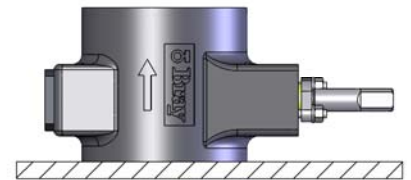

### INSTALLATION AND MAINTENANCE INSTRUCTIONS:

Before installing or performing any maintenance on the series 39 valve, it is strongly recommended that the procedures laid out in the installation and maintenance instructions be followed. There is no requirement for special tools to perform disassembly or reassembly maintenance on the Series 39 valve. Spare parts are available from your Bray distributor.

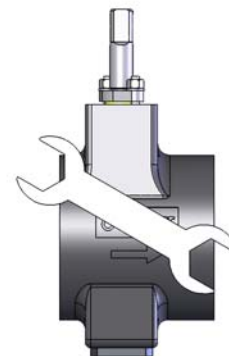

 奔達實業股份有限公司  
TEL:(07)375-8555 FAX:(07)375-8999  
公司：814 高雄市仁武區澄觀路 349 號

 **Bray** CONTROLS PACIFIC

All statements, technical information, and recommendations in this bulletin are for general use only. Consult Bray representatives or factory for the specific requirements and material selection for your intended application. The right to change or modify product design or product without prior notice is reserved.

A Division of BRAY INTERNATIONAL, Inc.  
8 Phoenix Crt, Braeside, Melbourne, VIC, 3195, Australia.  
PH: (613) 9580 9755 FAX: (613) 9580 8455 [www.bray.com](http://www.bray.com)  
Bray® is a registered trademark of BRAY INTERNATIONAL, Inc.  
© 2006 Bray International. All rights reserved. P-2023 4/06